

RB-214
RB-215

Core Drilling Machines

OPERATOR'S MANUAL

- Pour français voir page 13
- Para el castellano vea la página 27



WARNING!

Read this Operator's Manual carefully before using this tool. Failure to understand and follow the contents of this manual may result in electrical shock, fire and/or serious personal injury.

RIDGID[®]

Table of Contents

Recording Form for Machine Model and Serial Number	1
General Safety Information	
Work Area Safety	2
Electrical Safety	2
Personal Safety	2
Tool Use and Care	3
Service	3
Specific Safety Information	
Machine Safety	3
Description, Specifications and Equipment	
Description	4
Specifications	4
Machine Inspection	5
Machine and Work Area Set-Up	5
Securing Machine	
Bolt Anchor Method-to-Floor	6
Bolt Anchor Method-to-Wall	6
Vacuum Anchor Method-to-Floor	6
Ceiling Jack Anchor Method	7
Operating Instructions	7
Removing Cores	
Breaking a Core	8
Removing Broken Core Below the Surface	8
Removing Broken Core Stuck in Bit	8
Removing a Lodged Bit from Hole	8
Installing Bit Extension Rods	8
Accessories	
Accessories for Core Drilling Machines	8
Maintenance Instructions	
Lubrication	9
Ventilation	9
Motor Brush Replacement	9
Bit Replacement	9
Shims	9
Vacuum Seal	9
Machine Storage	9
Service and Repair	9
Wiring Diagrams	10
Lifetime Warranty	Back Cover



RB-214/215 Core Drilling Machine



Core Drilling Machines	
Record Serial Number below and retain product serial number which is located on nameplate.	
Serial No.	

General Safety Information

WARNING! Read and understand all instructions. Failure to follow all instructions listed below may result in electric shock, fire, and/or serious personal injury.

SAVE THESE INSTRUCTIONS!

Work Area Safety

- **Keep your work area clean and well lit.** Cluttered benches and dark areas invite accidents.
- **Do not operate power tools in explosive atmospheres, such as in the presence of flammable liquids, gases, or dust.** Tools create sparks which may ignite the dust or fumes.
- **Keep bystanders, children, and visitors away while operating a tool.** Distractions can cause you to lose control.

Electrical Safety

- **Grounded tools must be plugged into an outlet, properly installed and grounded in accordance with all codes and ordinances. Never remove the grounding prong or modify the plug in any way. Do not use any adapter plugs. Check with a qualified electrician if you are in doubt as to whether the outlet is properly grounded.** If the tools should electrically malfunction or break down, grounding provides a low resistance path to carry electricity away from the user.

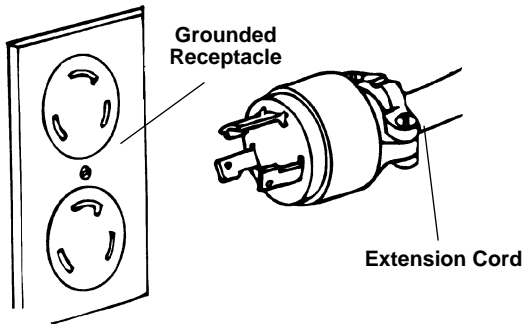

- **Avoid body contact with grounded surfaces.** There is an increased risk of electrical shock if your body is grounded.
- **Do not expose electrical tools to rain or wet conditions.** Water entering a tool will increase the risk of electrical shock.
- **Do not abuse cord. Never use the cord to carry the tools or pull the plug from an outlet. Keep cord away from heat, oil, sharp edges or moving parts. Replace damaged cords immediately.** Damaged cords increase the risk of electrical shock.

- **When operating a power tool outside, use an outdoor extension cord marked “W-A” or “W”.** These cords are rated for outdoor use and reduce the risk of electrical shock.
- **Use only three-wire extension cords which have three-prong grounding plugs and three-pole receptacles which accept the tool’s plug.** Use of other extension cords will not ground the tool and increase the risk of electrical shock.
- **Use proper extension cords.** (See chart.) Insufficient conductor size will cause excessive voltage drop, loss of power.

Minimum Wire Gauge for Extension Cord			
Nameplate Amps	Total Length (in feet)		
	0 – 25	26 – 50	51 – 100
0 – 6	18 AWG	16 AWG	16 AWG
6 – 10	18 AWG	16 AWG	14 AWG
10 – 12	16 AWG	16 AWG	14 AWG
12 – 16	14 AWG	12 AWG	NOT RECOMMENDED

- **Keep all electric connections dry and off the ground. Do not touch plugs or tool with wet hands.** Reduces the risk of electrical shock.

Personal Safety

- **Stay alert, watch what you are doing and use common sense when operating a power tool. Do not use tool while tired or under the influence of drugs, alcohol, or medications.** A moment of inattention while operating power tools may result in serious personal injury.
- **Dress properly. Do not wear loose clothing or jewelry. Contain long hair. Keep your hair, clothing, and gloves away from moving parts.** Loose clothes, jewelry, or long hair can be caught in moving parts.
- **Avoid accidental starting. Be sure switch is OFF before plugging in.** Carrying tools with your finger on the switch or plugging tools in that have the switch ON invites accidents.
- **Remove adjusting keys before turning the tool ON.** A wrench or a key that is left attached to a rotating part of the tool may result in personal injury.
- **Do not over-reach. Keep proper footing and balance at all times.** Proper footing and balance enables better control of the tool in unexpected situations.
- **Wear hearing protectors, ear plugs or muffs when using tool.** Noise level may affect hearing with prolonged use.
- **Use safety equipment. Always wear eye protec-**

tion. Dusk mask, non-skid safety shoes, hard hat or hearing protection must be used for appropriate conditions.

▲ WARNING Some dust created by power sanding, sawing, grinding, drilling and other construction activities contains chemicals known to the State of California to cause cancer, birth defects or other reproductive harm. Some examples of these chemicals are:

- lead from lead-based paints
- crystalline silica from bricks and cement and other masonry products
- arsenic and chromium from chemically-treated lumber

Your risk from these exposures varies, depending on how often you do this type of work. To reduce your exposure to these chemicals: work in a well ventilated area and work with approved safety equipment, such as those dust masks that are specially designed to filter out microscopic particles.

Tool Use and Care

- **Do not use if switch does not turn it ON or OFF.** Any tool that cannot be controlled with the switch is dangerous and must be repaired.
- **Disconnect the plug from the power source before making any adjustments, changing accessories or storing the tool.** Such preventive safety measures reduce the risk of starting the tool accidentally.
- **Store idle tools out of the reach of children and other untrained persons.** Tools are dangerous in the hands of untrained users.
- **Check for misalignment or binding of moving parts, breakage of parts and any other condition that may affect the tool’s operation. If damaged, have the tool serviced before using.** Many accidents are caused by poorly maintained tools.
- **Use only accessories that are recommended for your tool.** Accessories that may be suitable for one tool may become hazardous when used on another tool.
- **Keep handles dry and clean; free from oil and grease.** Allows for better control of the tool.

Service

- **Tool service must be performed only by qualified repair personnel.** Service or maintenance performed by unqualified repair personnel could result in injury.
- **When servicing a tool, use only identical replacement parts. Follow instructions in the Maintenance Section of this manual.** Use of unauthorized parts or failure to follow maintenance instructions may create a risk of electrical shock or injury.

Specific Safety Information

▲ WARNING!

Read this operator’s manual carefully before using the Core Drilling Machine. Failure to understand and follow the contents of this manual may result in electrical shock, fire and/or serious personal injury.

Call the Ridge Tool Company, Technical Service Department at (800) 519-3456 if you have any questions.

Machine Safety

- **Core Drilling Machine is made to drill holes in granite, masonry and steel reinforced concrete. Follow instructions on proper use of this machine. Do not use for other purposes.** Other uses or modifying this machine for other applications may increase the risk of serious injury.
- **Do not wear loose cloth gloves or loose clothing when operating machine. Wear only leather gloves. Keep sleeves and jackets buttoned. Do not reach across the machine or drill bit.** Clothing can be caught by the machine resulting in entanglement and serious injury.
- **Use extreme caution when drilling through floors. Provide protection of all personnel and material below the area.** Cores generally drop from the drill at completion of the hole.
- **Keep fingers and hands away from drill bit.** This practice will prevent entanglement and reduces risk of being cut.
- **Secure drill stand to the work surface. Use bolts, ceiling jack or vacuum hold-down. Do not secure with a vacuum hold-down when drilling on vertical surfaces such as walls.** Drill stand must be properly secured to prevent bit damage and serious injury.
- **When releasing carriage locking handle, maintain a firm grip on feed handle to prevent feed handle from revolving due to weight of drill.** Rotating handle can result in injury.
- **Do not force drill bit. Drill should be used at a speed and feed rate that does not overload the motor. When starting bits, do not use more than two 12” extensions.** Less likely to bind and lose control.

Description, Specifications and Standard Equipment

Description

The RIDGID No. RB-214 and RB-215 are heavy-duty Core Drilling Machines. Drilling bit sizes range from 1/2" through 14". The RB-214 Machine has a combination anchor/vacuum base which provides additional flexibility by incorporating both bases in one unit. The RB-215 has an anchor base only. The Diamond Core Bits are capable of drilling through granite, masonry and steel reinforced concrete.

Specifications

- Power Source.....30 amp, 115V, 60Hz
- Drill Motor Type 2.....2 Speed, 20 amp, 115V, 60Hz, Single Phase, 400/900 RPM
- Drilling Capacity1/2" through 14" w/Spacer
- Drill FeedingRack & Pinion Gear Type
- BaseAnchor Vacuum (13" x 17")
- Mast.....2 1/2" sq. x 42" high
- Slide Carriage.....Single Piece Aluminum
- Control Panel.....Box w/Amp-Meter, 2 Switches, 2 Outlets
- Vacuum System (RB-214 Only)Diaphragm Pump w/Vacuum Gauge
- Output Spindle ShaftThread Size 1 1/4-7 UNC
- Operation.....900 RPM – 1/2" - 4" Bits
400 RPM – 4" - 14" Bits

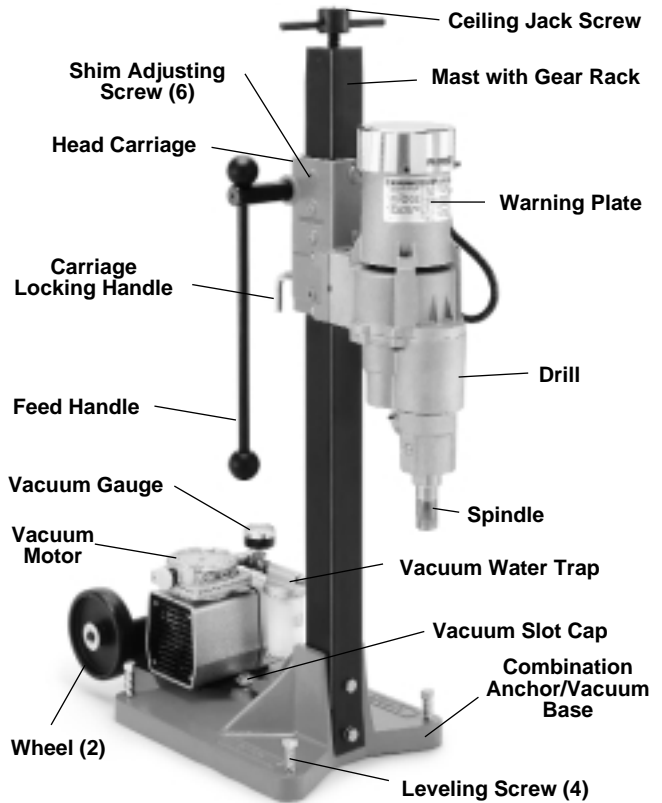

Figure 1A – RB-214 Core Drilling Machine

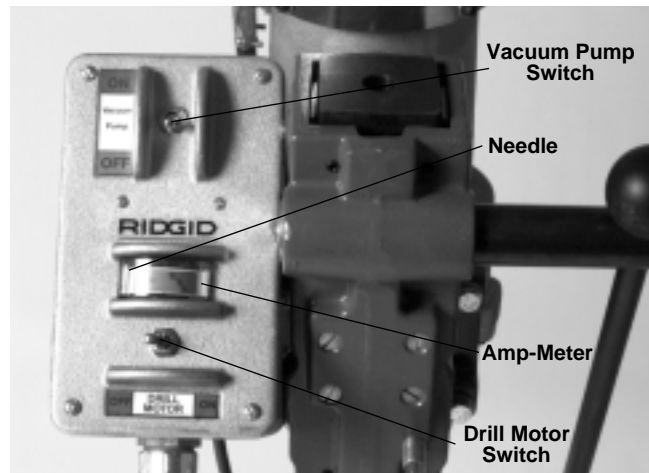

Figure 1B – RB-215 Core Drilling Machine

Machine Inspection

▲ WARNING!



To prevent serious injury, inspect your Core Drilling Machine. The following inspection procedures should be performed on a daily basis:

1. Make sure Core Drilling Machine is unplugged and the drill mast switch is set to the OFF position (*Figure 1*).
2. Inspect the vacuum seal for wear or damage. Replace if necessary.
3. Inspect the power cord and plug for damage. If the plug has been modified, is missing the grounding prong or if the cord is damaged, do not use the Threading Machine until the cord has been replaced.
4. Inspect the Core Drilling Machine for any broken, missing, misaligned or binding parts as well as any other conditions which may affect the safe and normal operation of the machine. If any of these conditions are present, do not use the machine until any problem has been repaired.
5. Lubricate the Core Drilling Machine if necessary according to the Maintenance Instructions.
6. Use drill bits and accessories that are designed for your Core Drilling Machine and meet the needs of your application. The correct tools and accessories allow you to do the job successfully and safely. Accessories designed for use with other equipment may be hazardous when used with this Core Drilling Machine.
7. Clean any oil, grease or dirt from all handles and controls. This reduces the risk of injury due to a tool or control slipping from your grip.

Inspect the cutting edges of your drill bits. If necessary, have them replaced prior to using the Core Drilling Machine. Bit is considered worn when the crown shows excessive wear and has become flush with tube. Dull or damaged cutting tools can lead to binding and tool breakage.

Machine and Work Area Set-Up

▲ WARNING!

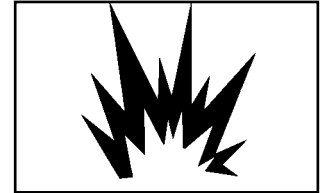

To prevent serious injury, proper set-up of the machine and work area is required. The following procedures should be following to set-up the machine.

1. Check that the work area has the following:
 - Adequate lighting.
 - No Flammable liquids, vapors or dust that may ignite.
 - Grounded electrical outlet.
 - Clear path to the electrical outlet that does not contain any sources of heat or oil, sharp edges or moving parts that may damage electrical cord.
2. Clean up the work area prior to setting up any equipment. Move tools and debris to prevent slips and falls.
3. Make sure drill motor ON/OFF switch is in the OFF position.
4. When plugging the Core Drilling Machine into the electrical outlet make sure to position the power cord along the clear path selected earlier. Use an extension cord in good condition.

▲ WARNING To avoid electrical shock and electrical fires, never use an extension cord that is damaged or does not meet the following requirements:

- The cord has a three-prong plug similar to shown in Electrical Safety section.
- The cord is rated as “W” or “W-A” if being used outdoors.
- The cord has sufficient wire thickness (12 AWG below 50’). If the wire thickness is too small, the cord may overheat, melting the cord’s insulation or causing nearby objects to ignite.

▲ WARNING To reduce risk of electrical shock, keep all electrical connections dry and off the ground. Do not touch plug with wet hands.

Securing Machine

⚠ WARNING!



Drilling machine must be properly secured to the work surface to prevent serious injury to the operator.

Movement during drilling will cause chatter of bit against work surface, fracturing diamonds. Bit may also bind in hole causing damage to the bit. Vacuum Anchor method should not be used to mount machine to a wall.

Bolt Anchor Method-to-Floor

1. Measure distance from center of anchor bolt slot in base (Figure 2) to center of drill spindle (Figure 1).
2. To locate the anchor bolt hole, use the distance obtained in Step 1 and measure from the center of the hole that is to be drilled.
3. Drill and set 1/2" anchor bolt. Place Drilling Machine over anchor hole and hand tighten anchor bolt.
4. Adjust 4 leveling screws (Figure 1) to stabilize base and plumb mast. Secure machine by tightening anchor bolt.

Bolt Anchor Method-to-Wall

Use the same bolt anchor method procedure to anchor as above.

⚠ WARNING Also fasten a chain to the Core Drilling Machine and secure the chain to prevent the machine falling and causing serious injury.

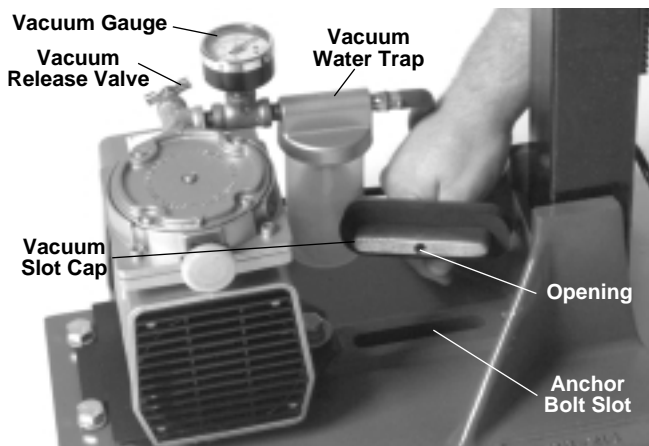

Figure 2 – Vacuum Motor and Base

Vacuum Anchor Method-to-Floor (RB-214 Only)

The Vacuum Anchor Method is recommended for 8" diameter holes or less. The Anchor Vacuum Method is NOT recommended on rough or cracked floor conditions, holes deeper than one bit length, or steel concentration greater than standard rebar.

⚠ WARNING Do not use Vacuum Anchor Method to mount machine to a wall.

1. Turn machine on its back and insert vacuum seal (Figure 3) under machine base, inspecting first to ensure seal is in good condition and sealing groove is clean.
2. Turn Drilling Machine up-right and loosen 4 base leveling screws.
3. Plug power cord into a properly grounded receptacle and turn vacuum pump ON/OFF switch to the ON position.
4. Insert vacuum slot cap into anchor bolt slot (Figure 2) and check vacuum and hose connections. Vacuum gauge (Figure 2) must read a minimum of 20" of mercury.
5. The drilling machine should now be vacuum anchored. If machine does not anchor, add weight by standing on vacuum base. It should now anchor with vacuum gauge reading 20" of mercury minimum. If not, check the floor and vacuum seal (Figure 3) for leaks.

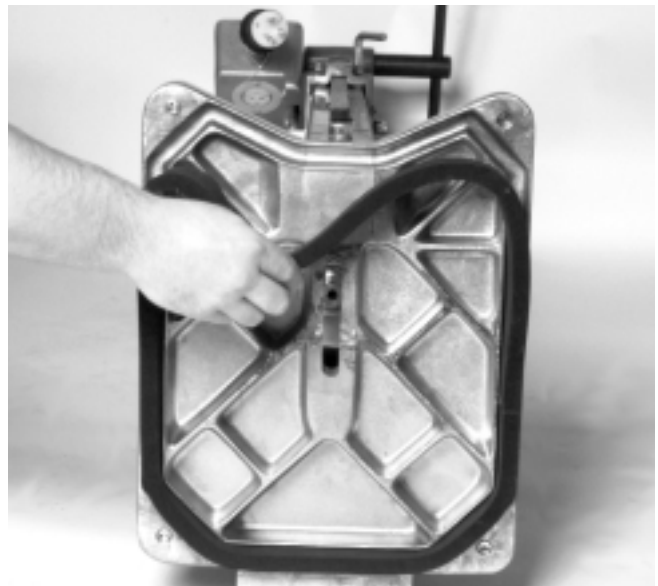

Figure 3 – Installing Vacuum Seal

6. Adjust 4 leveling screws to eliminate rocking and to stabilize machine and plumb mast. The machine is now ready to drill.

7. Frequently check the water level in the vacuum water trap. When water trap becomes half full, stop drilling and empty water.
8. After using, turn drill motor ON/OFF switch to the OFF position, then turn vacuum motor ON/OFF switch to the OFF position, unplug power cord and remove, clean and store vacuum seal.

NOTE! Vacuum can be released by turning vacuum release valve (Figure 2).

Ceiling Jack Anchor Method

1. Cut pipe or wood to the required length to fit between ceiling and ceiling jack screw (Figure 1) on top of mast.
2. Tighten ceiling jack screw to force machine against floor.
3. Stabilize and plumb machine by adjusting 4 leveling screws on base.

Operating Instructions

▲ WARNING!

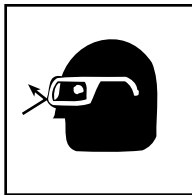

Do not wear cloth gloves or loose clothing when operating Drilling Machine. Keep sleeves and jackets buttoned. Do not reach across the machine. Keep hands and fingers away from drill bits.

Do not use this Drilling Machine if the ON/OFF switch or other controls are broken. Always wear eye protection to protect eyes from dirt and other foreign objects.

Do not use Drilling Machine if it is not securely anchored.

1. Thread the drilling bit (Figure 4) onto drilling spindle (Figure 1) and tighten securely with bit wrench.

▲ CAUTION Never turn drill ON with bit resting on the concrete.

2. Check hole alignment by lowering drill until it is about 1/2" from concrete.
3. Position 2-speed selector knob on drill to desired speed. Move selector down towards spindle to select high speed for up through 4" bits. Move selector up away from spindle to select low speed for bits

over 4". Make certain speed is proper for bit diameter being used.

▲ CAUTION DO NOT move speed selector while drill spindle is rotating.

NOTE! If a water collector ring and pump is used, plug pump into a properly grounded 115V receptacle. Have suitable container for draining.

4. With water control valve shut OFF. connect water inlet hose to drill and water source.

NOTE! Water can be supplied by a standard garden hose or by a pressure tank. Water is fed through inlet hose, down inside of bit, washing cuttings from under bit crown, up and outside of hole. Be sure that any method used has adequate water pressure to supply a flow of 1-2 gallons per minute. Lack of water can cause diamonds to polish or burn the bit causing bit end to turn blue.

5. With drill motor ON/OFF switch in OFF position, plug power cord into a properly grounded receptacle.
6. Open water control valve allowing water to flow at 1-2 gallons per minute.

▲ WARNING Before turning drill motor ON, be certain that machine is securely anchored.

7. Turn drill motor ON/OFF switch to ON position.

▲ CAUTION DO NOT apply full load until entire bit crown has penetrated the material.

8. Turn feed handle to apply load on bit. To prevent bit from wandering, apply light pressure on feed handle while starting to drill.

NOTE! The AMP-meter has a green and red area to indicate proper pressure and drilling speed, preventing motor overload and providing longer bit life. The green area is the working range; the red area indicates too much pressure being applied. Keep Amp-meter needle in the green area. Too little pressure can polish bit and too much can cause undue wear.

9. Drill bit feed should be uniform without excessive force. Drilling penetration of 1" to 4" per minute may be achieved in concrete depending on material and bit diameter. Proper feed pressure is determined by load on motor and reading on Amp-meter. To maximize life of drill bit, regulate feed rate so that needle on Amp-meter is in upper green area of 20 amp range. If needle goes into red area above 20 amps, decrease feed rate as undue bit wear will result.

NOTE! If the cooling water turns clear, it is an indication you are drilling through rebar.

10. Your control panel amp-meter will go into the red area when you hit steel. When you encounter rebar, lessen feed rate to allow needle to return to the green area.

NOTE! It is recommended that after cutting steel, you stop and break out core and any loose pieces of steel, then proceed.

▲ CAUTION When drilling steel embedded in concrete, never switch to HIGH speed if you are drilling in LOW speed. These bits are not designed to drill through solid steel.

▲ WARNING Use extreme care when drilling through floors. Provide for protection of all personnel and material below the area. Cores generally drop from drill bit at completion of the hole.

Removing Cores

Breaking a Core

1. If you are not drilling completely through, the core can be easily broken by inserting a screwdriver into the drilled groove and prying the core to the opposite side.
2. Use a second screwdriver to lift core out.

Removing Broken Core Below the Surface

1. Use a 1/8 inch diameter steel rod.
2. Make a 1/4 inch long 90° bend at one end.
3. Insert rod down side of broken core to depth of break, twist 90° and lift core out.

Removing Broken Core Stuck In Bit

▲ WARNING Unplug machine cord from power source.

1. Increase water pressure and try to free core with your hands.
2. If unable to free core, remove bit from drill.
3. Push core gently through from top of bit with a rod using a capped bit.

Removing a Lodged Bit from Hole

▲ WARNING Unplug machine cord from power source.

1. Turn Water ON.
2. Using bit wrench, try to rotate bit in both directions and lift out using feed handle.
3. If unable to free bit, turn water OFF and disconnect bit from drill spindle. Use bit wrench again, rotating back and forth and rocking until free.

Installing Bit Extension Rods

In order to drill deeper than the 13" long bit will allow, bit extension rods must be used. Drilling rate will be slower because of the extra amount of drag on the bit walls.

NOTE! When it is necessary to place the drilling machine above the surface being drilled, do not use a bit extension rod that is longer than 12".

1. Drill to full depth of bit.
2. Back drill out and remove bit and core.
3. Put drill bit back into hole and connect a 4, 6 or 12" bit extension rod to bit and secure with spindle wrench.
4. Screw bit extension rod onto drill spindle and secure with spindle wrench.
5. Proceed with drilling.

Accessories

▲ WARNING Only the following RIDGID products have been designed to function with the Core Drilling Machine. Other accessories designed for use with other tools may become hazardous when used on this machine. To prevent serious injury, use only the accessories listed below.

Accessories for Core Drilling Machines

- Small Anchor Base (7" x 12")
- Anchor-Vacuum Base (13" x 17")
- Anchor-Vacuum Drill Stand
- Vacuum Motor (115V) 60Hz
- Vacuum Motor (230V) 50Hz Export
- Vacuum Motor with Fittings (115V) 60Hz
- Vacuum Motor with Fittings (230V) 50Hz
- Control Panel (115V)
- Control Panel (230V)
- 2" Spacer Block (Applications Over 10")
- 20 Amp (115V) 25-60Hz, 450/1200 RPM Motor
- 10 Amp (230V) 25-60Hz, 450/1200 RPM Motor
- Spindle Wrench
- Water Collector & Pump (115V)
- Water Collector & Pump (230V)
- Water Collector Ring
- Water Pump (115V) 50-60Hz
- Water Pump (230V) 50-60Hz

NOTE! See Ridge Tool catalog or a Ridge distributor for a complete list of Core Drill Bits, Adapters and Bit Extensions.

Maintenance Instructions

▲ WARNING Make sure machine is unplugged from power source before performing maintenance or making any adjustment.

Lubrication

Keep a light coating of oil on rack and pinion and drill spindle.

Ventilation

Keep drill motor inlet and air passage clear to assure proper motor ventilation.

Motor Brush Replacement

Check motor brushes every 200 hours and replace when brushes become 1/4 inch or less in length.

Bit Replacement

Bit is considered worn when the crown shows excessive wear and has become flush with tube.

Shims

Carriage head will become loose due to vibrations. Tighten shim adjusting screws to remove *play*.

Vacuum Seal

Replace vacuum seal if it becomes mushroomed on bottom edge, cracked, pitted, or worn.

Machine Storage

Motor-driven equipment must be kept indoors or well covered in rainy weather. Always remove vacuum seal from base of machine. Store the machine in a locked area that is out of reach of children and people unfamiliar with drilling machines. This machine can cause serious injury in the hands of untrained users.

Service and Repair

▲ WARNING!



Service and repair work on this Core Drilling Machine must be performed by qualified repair personnel. Machine should be taken to a RIDGID Independent Authorized Service Center or returned to the factory. All repairs made by Ridge service facilities are warranted against defects in material and workmanship.

When servicing this machine, only identical replacement parts should be used. Failure to follow these instructions may create a risk of electrical shock or other serious injury.

If you have any questions regarding the service or repair of this machine, call or write to:

Ridge Tool Company
 Technical Service Department
 400 Clark Street
 Elyria, Ohio 44035-6001
 Tel: (800) 519-3456
 E-mail: TechServices@ridgid.com

For name and address of your nearest Independent Authorized Service Center, contact the Ridge Tool Company at (800) 519-3456 or <http://www.ridgid.com>

Wiring Diagram (115V, 60Hz)

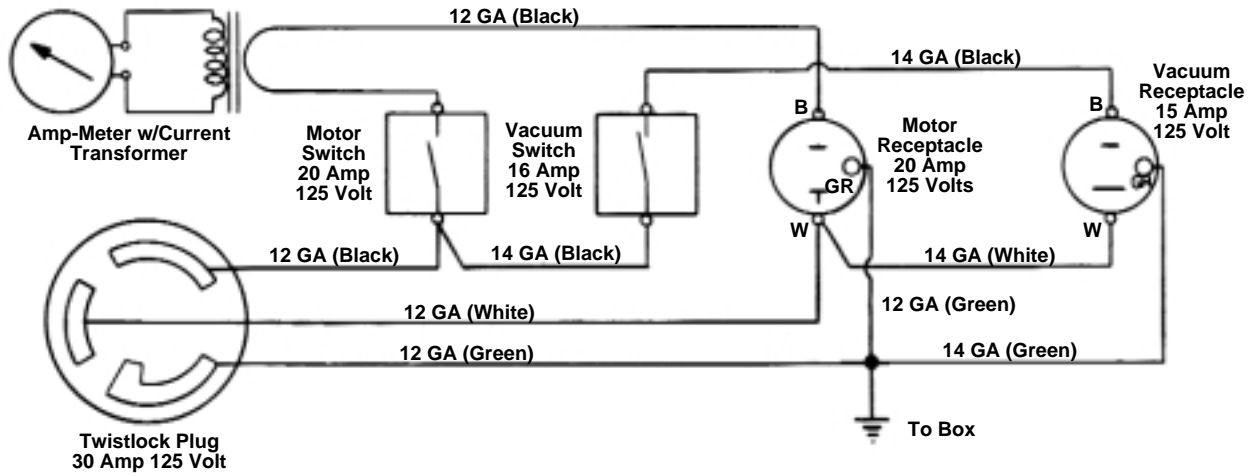

Wiring Diagram (230V, 50-60Hz) - Australia and Europe

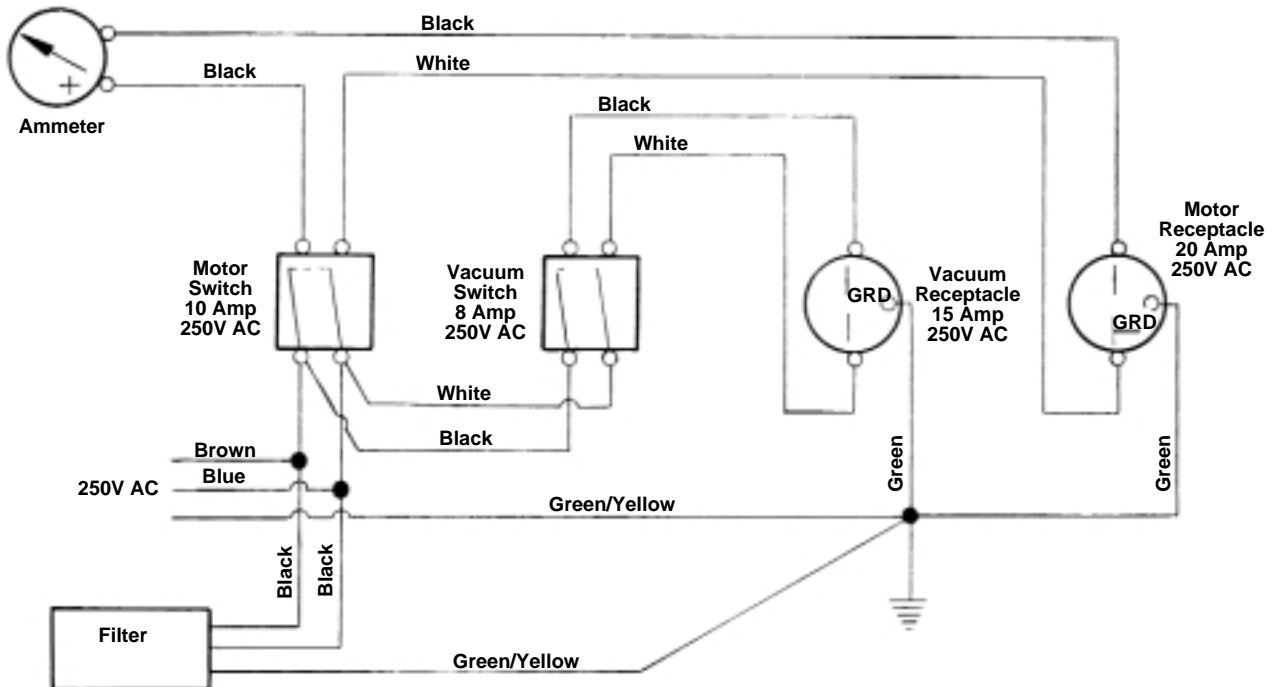

Wiring Diagram (230V, 50-60Hz) - Cat. No. 16597

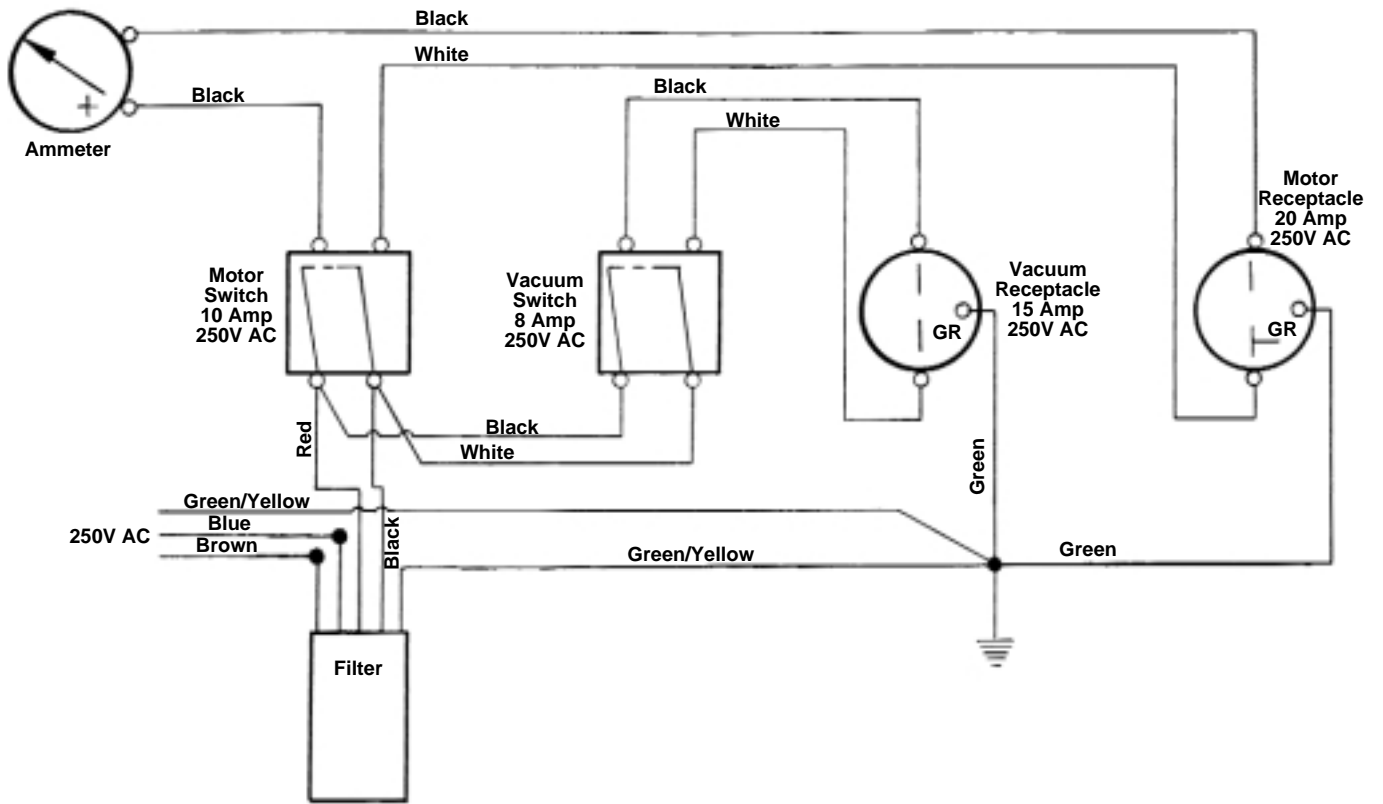



What is covered

RIDGID® tools are warranted to be free of defects in workmanship and material.

How long coverage lasts

This warranty lasts for the lifetime of the RIDGID® tool. Warranty coverage ends when the product becomes unusable for reasons other than defects in workmanship or material.

How you can get service

To obtain the benefit of this warranty, deliver via prepaid transportation the complete product to RIDGE TOOL COMPANY, Elyria, Ohio, or any authorized RIDGID® INDEPENDENT SERVICE CENTER. Pipe wrenches and other hand tools should be returned to the place of purchase.

What we will do to correct problems

Warranted products will be repaired or replaced, at RIDGE TOOL'S option, and returned at no charge; or, if after three attempts to repair or replace during the warranty period the product is still defective, you can elect to receive a full refund of your purchase price.

What is not covered

Failures due to misuse, abuse or normal wear and tear are not covered by this warranty. RIDGE TOOL shall not be responsible for any incidental or consequential damages.

How local law relates to the warranty

Some states do not allow the exclusion or limitation of incidental or consequential damages, so the above limitation or exclusion may not apply to you. This warranty gives you specific rights, and you may also have other rights, which vary, from state to state, province to province, or country to country.

No other express warranty applies

This FULL LIFETIME WARRANTY is the sole and exclusive warranty for RIDGID® products. No employee, agent, dealer, or other person is authorized to alter this warranty or make any other warranty on behalf of the RIDGE TOOL COMPANY.

Ridge Tool Company
400 Clark Street
Elyria, Ohio 44035-6001



Ce qui est couvert

Les outils RIDGE® sont garantis contre tous vices de matériaux et de main d'oeuvre.

Durée de couverture

Cette garantie est applicable durant la vie entière de l'outil RIDGE®. La couverture cesse dès lors que le produit devient inutilisable pour raisons autres que des vices de matériaux ou de main d'oeuvre.

Pour invoquer la garantie

Pour toutes réparations au titre de la garantie, il convient d'expédier le produit complet en port payé à la RIDGE TOOL COMPANY, Elyria, Ohio, ou bien le remettre à un réparateur RIDGID® agréé. Les clés à pipe et autres outils à main doivent être ramenés au lieu d'achat.

Ce que nous ferons pour résoudre le problème

Les produits sous garantie seront à la discrétion de RIDGE TOOL, soit réparés ou remplacés, puis réexpédiés gratuitement ; ou si, après trois tentatives de réparation ou de remplacement durant la période de validité de la garantie le produit s'avère toujours défectueux, vous aurez l'option de demander le remboursement intégral de son prix d'achat.

Ce qui n'est pas couvert

Les défaillances dues au mauvais emploi, à l'abus ou à l'usure normale ne sont pas couvertes par cette garantie. RIDGE TOOL ne sera tenue responsable d'aucuns dommages directs ou indirects.

L'influence de la législation locale sur la garantie

Puisque certaines législations locales interdisent l'exclusion des dommages directs ou indirects, il se peut que la limitation ou exclusion ci-dessus ne vous soit pas applicable. Cette garantie vous donne des droits spécifiques qui peuvent être éventuellement complétés par d'autres droits prévus par votre législation locale.

Il n'existe aucune autre garantie expresse

Cette GARANTIE PERPETUELLE INTEGRALE est la seule et unique garantie couvrant les produits RIDGID®. Aucun employé, agent, distributeur ou tiers n'est autorisé à modifier cette garantie ou à offrir une garantie supplémentaire au nom de la RIDGE TOOL COMPANY.



Qué cubre

Las herramientas RIDGID están garantizadas contra defectos de la mano de obra y de los materiales empleados en su fabricación.

Duración de la cobertura

Esta garantía cubre a la herramienta RIDGID durante toda su vida útil. La cobertura de la garantía caduca cuando el producto se torna inservible por razones distintas a las de defectos en la mano de obra o en los materiales.

Cómo obtener servicio

Para obtener los beneficios de esta garantía, envíe mediante porte pagado, la totalidad del producto a RIDGE TOOL COMPANY, en Elyria, Ohio, o a cualquier Servicentro Independiente RIDGID. Las llaves para tubos y demás herramientas de mano deben devolverse a la tienda donde se adquirieron.

Lo que hacemos para corregir el problema

El producto bajo garantía será reparado o reemplazado por otro, a discreción de RIDGE TOOL, y devuelto sin costo; o, si aún resulta defectuoso después de haber sido reparado o sustituido tres veces durante el período de su garantía, Ud. puede optar por recibir un reembolso por el valor total de su compra.

Lo que no está cubierto

Esta garantía no cubre fallas debido al mal uso, abuso o desgaste normal. RIDGE TOOL no se hace responsable de daño incidental o consiguiente alguno.

Relación entre la garantía y las leyes locales

Algunos estados de los EE.UU. no permiten la exclusión o restricción referente a daños incidentales o consiguientes. Por lo tanto, puede que la limitación o restricción mencionada anteriormente no rija para Ud. Esta garantía le otorga derechos específicos, y puede que, además, Ud tenga otros derechos, los cuales varían de estado a estado, provincia a provincia o país a país.

No rige ninguna otra garantía expresa

Esta GARANTIA VITALICIA es la única y exclusiva garantía para los productos RIDGID. Ningún empleado, agente, distribuidor u otra persona está autorizado para modificar esta garantía u ofrecer cualquier otra garantía en nombre de RIDGE TOOL COMPANY.